

FEDERAL SUPPLY CLASS

RATIONALE

REVISE THREAD SPECIFICATION TO AS8879. REVISE LIGHTENING HOLE CONFIGURATION (ADD SECTION VIEW) TO ALLOW OPTIONAL SHAPE AT BOTTOM OF HOLE, DELETE .015 MAX RADIUS AT BASE OF WRENCH PAD, UPDATE FPI REQUIREMENTS, ADD SURFACE FINISH REQUIREMENTS TO BOLT HEAD, ADD AS3062 FOR THREAD RUNOUT, ADD MIN. BEARING DIA, DELETE METRIC DIMENSIONS, UPDATE ANSI Y14.5-1973 TO ANSI Y14.5M- 1982, GENERAL EDITORIAL UPDATE, REFERENCES UPDATED AND FIGURE 1 REDRAWN.

REV. A

AS3173™

SAE Technical Standards Board Rules provide that: "This report is published by SAE to advance the state of technical and engineering sciences. The use of this report is entirely voluntary, and its applicability and suitability for any particular use, including any patent infringement arising therefrom, is the sole responsibility of the user." SAE invites your written comments and suggestions.

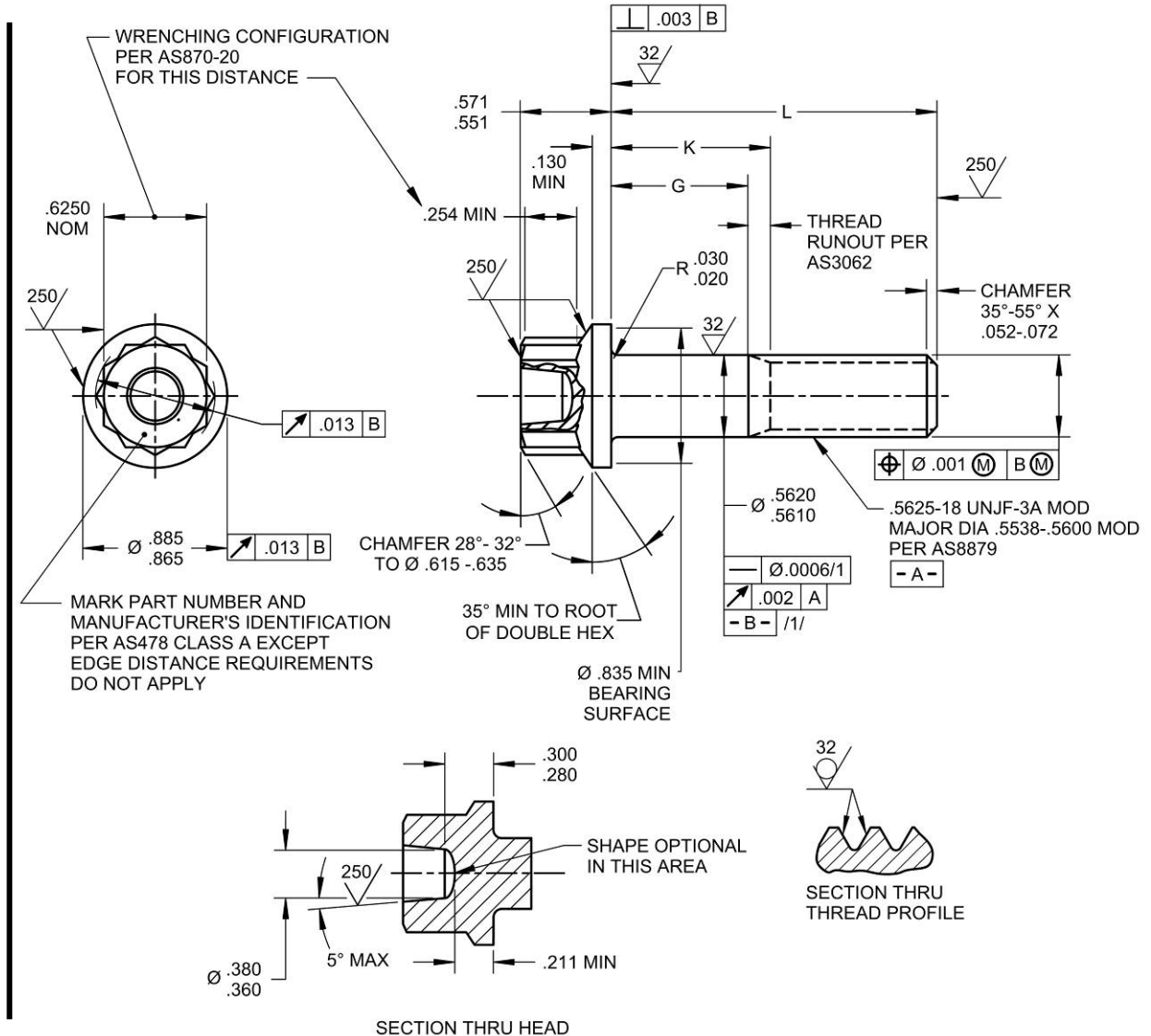
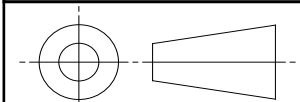

FIGURE 1 - BOLT

SAE values your input. To provide feedback on this Technical Report, please visit <http://standards.sae.org/AS3173A>

THIRD ANGLE PROJECTION



CUSTODIAN: E-25

PROCUREMENT SPECIFICATION:



AEROSPACE STANDARD

BOLT, MACHINE - DOUBLE HEX EXTENDED WASHER HEAD, CLOSE TOLERANCE SHANK, AMS5643 (UNS S17400), 140 KSI, .5625-18, UNJF-3A

AS3173™ SHEET 1 OF 3

REV. A

ISSUED 1976-03 REVISED 2013-09 REAFFIRMED 2018-11